

XAG P100 PRO SPREADER DRONE



21 gal

Dry Box

110 lbs

Payload

10 - 23 ft

Swath

330 lbs/min

Spread Rate

22 acre/hr

70 lbs / load
35 lbs / acre
3 loads / flight



Folding Arms

Save 65% of Space for
Transportation and Storage

Assisted Manual Fly

Flight Lane Assist
One tap to change Lane
Adaptive Spray Rate Control

55" Blade

More powerful Motor
110 lbs payload

264 ft Detect Range

4D Obstacle Avoidance
Radar



800-345-3546
gvm-dist.com

XAG ADVANCING
AGRICULTURE

Unique Auger feeding design

- Accurate feeding
- No damage to payload granule
- Well-distributed feeding
- No clogging

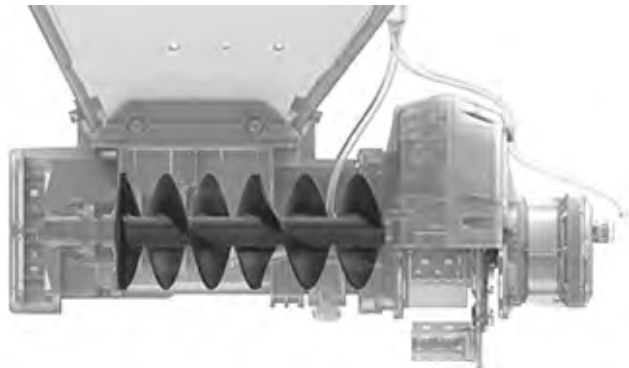

Different size for various jobs

- 4 sizes of auger for jobs from seeding, fertilizing, and feeding
- 1-6 mm (very coarse to fine) granule size
- Easily and quickly change auger in 1 minute
- Easy to clean with water



Two powerful Auger Motors

- Grind granule clog without stopping the operation
- Adaptive variable spreading speed by flight speed
- Detachable auger and motor module for easy maintenance

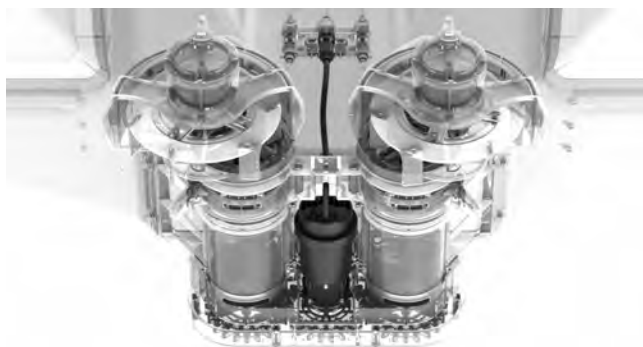

Vertical spreading head reinforced by stainless steel

- Corrosion resistance spreading head
- Better swath control with vertical spreading
- Eject payload into soil vertically

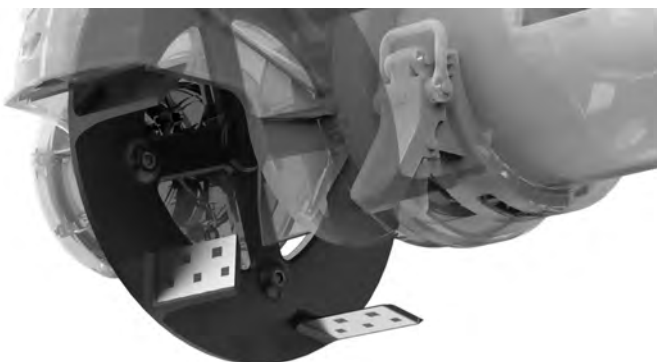

Variable Spreading

Intelligent auger feeder, which can also automatically control the feeding amount according to the flight speed, achieving real-time variable spreading, resulting in a more even distribution



Level Sensor

- Non-touching radar sensor without corrosion risk
- Real-time sensing granule level
- Stop feeding when the payload is empty
- Prevent missing spreading

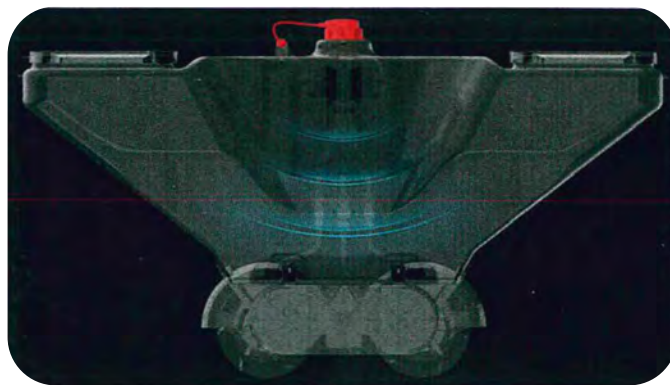

800-345-3546
gvm-dist.com

XAG ADVANCING
AGRICULTURE